



Chroma-Q™ Color Charge Plus™ LED Fixture

Part No: CHCCPRGBA

S P E C I F I C A T I O N S H E E T

V 1.0

DESCRIPTION

The fixture shall provide a portable, battery powered LED lighting source.

The battery shall be NIMH.

The head shall be focusable over a range greater than 90°.

The fixture shall be suitable for a wide range of indoor temporary lighting applications.

The fixture shall provide wireless and wired control.

The fixture shall provide a master slave mode via wireless signal.

The fixture shall provide RGBA colour mixing.

The fixture shall provide a high CRI of 92.

The fixture shall provide 900 hot lumens output.

The fixture shall provide up to 30 hours usage from a single battery charge.

The fixture shall have a gas gauge.

The fixture shall provide a smooth, linear dimming curve.

The fixture shall offer a choice of RGB, RGBA, St RGBI (*Magic Amber™) and Fx HSI control modes.

The fixture shall feature a built-in stand-alone mode with real-time triggering.

The fixture shall be manufactured from partially recyclable materials.

The fixture shall be fanless.

The fixture shall provide operation as a wireless receiver and transmitter.

FEATURES

- 900 lumens output – super bright for a battery powered fixture
- 50% more light output than original Color Charge
- Battery powered LED fixture - no need for mains power
- Long battery life - NiMH battery lasts up to 30 hours
- Long product life - up to 1,000 battery recharges
- Wireless control and syncing between units - no cables
- RGBA - improved colour rendition and a wider colour range
- High CRI of 92
- Theatrical grade dimming
- Future proof - interchangeable head
- Green design

OVERALL SPECIFICATIONS

Net dimensions (without fixings):	Width: 140mm / 5.5" Height: 230mm / 9" Depth: 280mm / 11"
Net weight:	7.5kg / 16lbs
Shipping dimensions	Width: 330mm / 13" Height: 304mm / 12" Depth: 190mm / 7.5"
Shipping weight:	8kg / 18lbs

OVERALL SPECIFICATIONS cont.

Power (for charging only):	100-240V AC, 50-60 Hz, 160VA
Power connector in/out:	IEC
Data connector in/out:	XLR 5-pin
Control protocol:	ANSI E1.11 DMX-512A, Wireless W-DMX / XLR 5-pin in / through
Cooling system:	Convection
Construction:	Anodised aluminium extrusion
Colour:	Black
Built-in hardware:	1/2" nutsert, Kensington lock slot
IP rating:	IP20
Approvals:	CISPR 22 :2006/EN55022 :2006 CISPR 24 :1997/EN55024 :1998 ICES-003 :2004 & FCC Part 15 Subpart B: 2007, CSA C22. No. 166-M1983: R2008 UL 1573:2003; UL 8750
LED cells:	1
Total LEDs:	12
Control modes:	5 channels St RGBI (*Magic Amber), 5 channels Fx HSI, 3 channels RGB, 4 channels RGBA, 1 channel DMX Look Select, Demo, Stand-alone Master Theatrical
Dimming curve:	Yes
Variable effects engine:	Yes
Effects parameters:	Colour speed, colour fan, colour range, colour step, intensity effects and intensity fan
Hot lumen output:	White 900 lumen Red 132 lumen Green 475 lumen Blue 46 lumen Amber 117 lumen
Optics:	Specialised close focus lens
Beam angle:	22° (Approx.)
Beam distribution:	Symmetrical direct illumination
CCT:	Adjustable 1,000 - 10,000K
Colour gamut:	Performance enhanced
CRI:	92
Lamp life:	L70 at 50,000 hours

ORDERING INFORMATION

Model	Part No
Chroma-Q Color Charge Plus RGBA	CHCCPRGBA

ACCESSORIES

Model	Part No
Chroma-Q Half Hat Snoot for Color Charge	CHCCHHS
Chroma-Q Power Cradle to Take 3 Color Charge Units	CHCCCI
Chroma-Q Replacement Battery Pack For Color Charge	CHCCBP



*Magic Amber is the term used for the unit's ability to bring in amber when mixing colours that require it.

www.chroma-q.com



HQ, UK & International Sales
A.C. Entertainment Technologies Ltd.
Tel: +44 (0)1494 446000
Fax: +44 (0)1494 461024
sales@ac-et.com
www.ac-et.com

Northern UK Sales
A.C. Entertainment Technologies Ltd.
Tel: 0113 255 7666
Fax: 0113 255 7676
acnorth@ac-et.com
www.ac-et.com

North American Sales
A.C. Lighting Inc.
Tel: 416-255-9494
Fax: 416-255-3514
northamerica@aclighting.com
www.aclighting.com/northamerica

Asian Sales
A.C. Lighting Asia KK
Tel: +81 (0)48-475-9377
Fax: +81 (0)48-475-9355
asia@aclighting.com
www.aclighting.com/asia



Chroma-Q™ Color Charge Plus™ LED Fixture

Part No:
CHCCPRGBA

S P E C I F I C A T I O N S H E E T

V 1.0

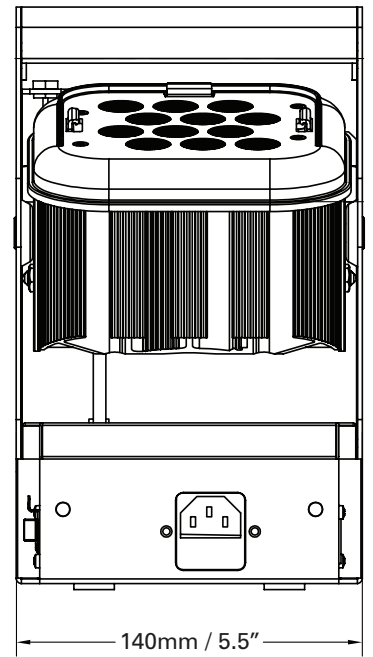
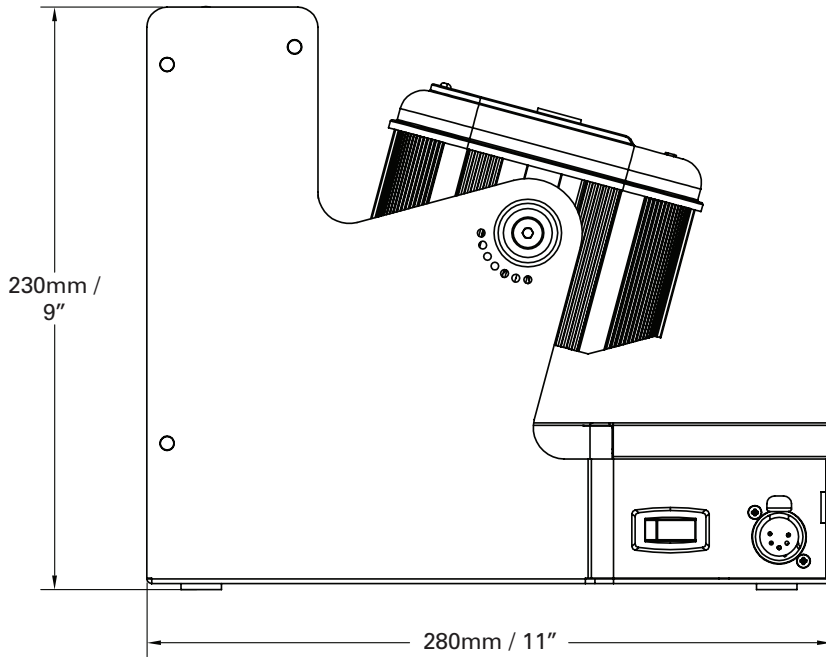
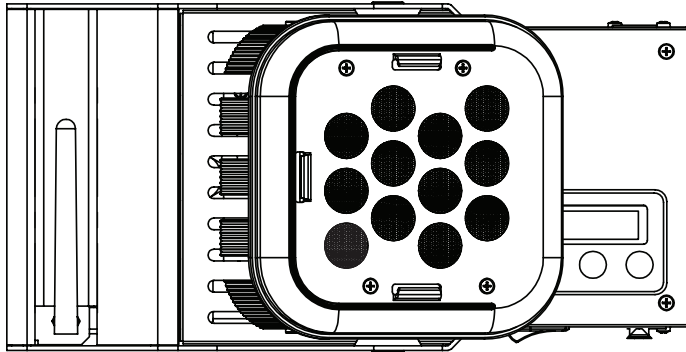

www.chroma-q.com



HQ, UK & International Sales
A.C. Entertainment Technologies Ltd.
Tel: +44 (0)1494 446000
Fax: +44 (0)1494 461024
sales@ac-et.com
www.ac-et.com

Northern UK Sales
A.C. Entertainment Technologies Ltd.
Tel: 0113 255 7666
Fax: 0113 255 7676
acnorth@ac-et.com
www.ac-et.com

North American Sales
A.C. Lighting Inc.
Tel: 416-255-9494
Fax: 416-255-3514
northamerica@aclighting.com
www.aclighting.com/northamerica

Asian Sales
A.C. Lighting Asia KK
Tel: +81 (0)48-475-9377
Fax: +81 (0)48-475-9355
asia@aclighting.com
www.aclighting.com/asia

Chroma-Q and all associated product names are recognised trademarks, for more information visit www.chroma-q.com/trademarks. The rights and ownership of all trademarks are recognised. The information contained herein is correct at the time of printing, however as we are constantly refining our product range we reserve the right to change the specification without notice. E60E.